



**LONDON
LEGENDS**

PRESENTS

**The London Legends GT
2026**

**A Warhammer Fantasy 8th Edition
Tournament**

13-14th June 2026

Greetings Wargamer! We invite you to attend The LONDON LEGENDS GT 2026, a Warhammer Fantasy 8th Edition tournament to be held at the Dark Sphere Megastore at London Shepherd's Bush on the 13-14th June 2026.

Your comp organisers – with over 181 years of competitive Warhammer experience between them - will be [Dr Luke Blaxill](#), [Simon Hughes](#), and Mark 'Knoffles' Merfield.

The legend of Warhammer arguably began right here in Shepherd's Bush. Four decades ago just up the Uxbridge Road, the original LONDON LEGENDS Steve Jackson and Ian Livingstone began Games Workshop, running it out of their flat. And down the road in Hammersmith, the first Games Workshop store was opened a few years later.

We will have five rounds of 2hrs 45 mins.

There will be prizes for first, second, and third places, a Best Painted prize (chosen by the organisers), and a prize for Best Themed Army

The ticket price is £45, which includes lunch (Domino's pizza) on both days.

You can buy tickets by making a payment in full to the following PayPal account: <https://paypal.me/londonlegends> and sending an email to londonlegendswarhammer@gmail.com with the name of all attendees.

Refund Policy: Any request for a refund within 4 weeks of the event will only be possible if there is a reserve list of players who can take up that place. Note that this is a change from last year to allow time to find players to step in at short notice.

The Venue:

The Event will be held at Dark Sphere, W12 Shopping Centre, Shepherd's Bush, London, W12 8PP.

It is located on the ground floor. Limited refreshments are available from the store, but an extensive range of options for breakfast and luncheon can be found in the W12. Note that the venue itself does not have toilets - these can be found outside the store just past Lidl.

The W12 is across the road from Shepherd's Bush Station (not to be confused with Shepherd's Bush Market!) which is on the Central Line and Overground.

Parking is available in the W12 and you can see the prices here: <https://west12shopping.co.uk/your-visit/getting-here>

Parking is also available in the Westfield shopping centre but note that this is around a 5-7min walk from the W12. <https://uk.westfield.com/london/access>

Schedule

Saturday:

9:45am registration

1000-1245 – Game 1

1245-1315 – Lunch

1315-1600 – Game 2

1600-1630 – Break

1630-1915 – Game 3

Sunday:

1015-1300 – Game 4

1300-1345 – Lunch and best painted setup

1345-1630 – Game 5

1630 – Awards

Tournament Key Points:

This is a Warhammer Fantasy Battle 8th Edition Tournament at 2500 points. We will be using 25% lords and 25% heroes as per the original Warhammer rules.

Unpainted Armies will be accepted, although painted armies will be rewarded with bonus TPs.

All the final Warhammer 8th edition GW Armies will be allowed at this event including: Beastmen (7th edition book), Bretonnia (6th edition book), Daemons of Chaos, Dark Elves, Dwarfs, High Elves, Lizardmen, Ogre Kingdoms, Orcs and Goblins, Skaven (7th edition book), The Empire, Tomb Kings, Vampire Counts, Warriors of Chaos and Wood Elves, in addition to Legion of Azgorh - Chaos Dwarfs - from the Tamurkhan book.

End Times lists, units, and characters and any other models not covered in above army books are **not allowed**. (Note that Beastmen are allowed to use some rules from End Times as described in the army composition section below).

This year we are experimenting with a 'back to basics' approach and therefore will not be using additional units from the Monstrous Arcanum and Storm of Magic, nor any of the units from the Tamurkhan book outside of the Legions of Azgorh roster. We will gather feedback on whether to keep this change in subsequent events.

Third party models and Proxy models or Conversions are allowed if it is clear to your opponents what the model is now representing and is on the correct base size.

If you have rebased your army for Warhammer The Old World then worry not. Rebased armies will be legal at this event (though it may put you at a slight disadvantage!).

If you are unsure about the legality of any model or base size, please ask by sending an email to: londonlegendswarhammer@gmail.com

Building your Army:

Time for fun and games.. This is a 2500pts event.

Please be aware that all army lists for this event will need to have the following:

- Your Name at the top
- The name of the faction you are intending to use
- Your Comp Score
- Unit (points), General, Magic Lore, Upgrades (points), Total points
- Your Armies total points cost

Your list will need to be submitted to londonlegendswarhammer@gmail.com by **11.59pm on Saturday 23rd May**. Late submission will result in a **5 TP deduction** from your final event score! You may use Battlescribe, Army Builder, or any other intelligible format to submit your list.

This is an **OPEN LISTS** event and the lists will be published approximately one week before the event on the London Legends GT Facebook [event page](#).

House Rules

- The Battle Standard Bearer may take mundane items available to normal heroes of their type.
- Magic Resistance saves may be taken vs Purple Sun (Note this is just magic res and doesn't stack with any other ward. The maximum save possible is a 4+ save).
- One model in a unit may benefit from a look out sir roll against the following spells: The Dwellers Below, Final Transmutation & The Dreaded 13th.
- True line of sight will be used. Hills and impassable terrain are considered infinitely high and therefore block LoS. This means that a unit that is just partially on a hill can be seen from the ground and a unit behind a hill cannot be seen.
- Max 12 Power Dice can be used in a SINGLE Magic Phase. (Night Goblin Magic Mushrooms are not power dice, as per their Armybook. Warpstone Tokens are treated as Power Dice.)
- A maximum of 5 dice may be used when casting any spell. (Night Goblin Magic Mushrooms are not power dice, as per their Armybook. Warpstone Tokens are treated as Power Dice.)
- Multiple Wound Attacks: Attacks that cause Multiple Wounds on units with multiple wound models are applied on one model at a time, and any excess wounds are wasted. For example: A Model with Multiple Wounds D6 is fighting a unit of multi-wound models (i.e.

Kroxigor: with the assumption that each Kroxigor in the unit is at its full 3 wounds). After scoring 4 wounds, they roll the Multi-Wound D6s: 6, 5, 2, 2. This will result 3 dead Kroxigor. The 6 kills one Kroxigor outright and the remaining 3 are wasted. The 5 kills one Kroxigor outright and the remaining 2 are wasted. The 2 takes off 2 wounds from one Kroxigor and the final 2 takes of the remaining wound from that Kroxigor and 1 wound is wasted.

- Buildings can be garrisoned by up to 20 wounds worth of models. This includes 'magical' buildings such as the Folding Fortress.
- All ambushers (and the Green Knight) automatically enter the battle on turn 5 if they have failed to appear on turns 1-4.
- Ridden monsters count as having 1 rank for the purposes of steadfast (and breaking steadfast)
- Cannons that hit a ridden monster must randomise between the monster and rider and the cannon will only hit one (1-4 monster, 5-6 rider).
- Ridden monsters and riders will give up VPs separately
- If a unit is at 25% or below, or fleeing, at the end of the game, the opposing player will get half victory points for that unit. Note that a single model must be fleeing at the end of the game to qualify for half VPs.
- The Green Knight will give up half VPs the first time he is killed and the other half if he is not on the board at the end of the game.
- Models with the Colossal Beast rule can be wounded by attacks <S4 (this will not be relevant for London Legends 2026)
- **Special characters that are both your General and BSB will be able to break and flee from combat as normal as therefore will not automatically be removed when breaking from combat like other BSBs.**

The Comp:

Your army starts at 0 (unless otherwise stated). Add or subtract as instructed to get your final score with the following conditions:

Your score has a max upper limit of +10 but no lower limit.

You cannot gain a plus bonus for duplicates of the same unit.

Your total comp score will be used in two ways:

1. Your first game opponent will not be random but will be matched on your comp score. If I have a +5 list, I will be playing someone in game 1 with as close a comp score as possible. (Swiss pairing will match opponents after round 1).
2. At the end of the tournament your comp score will be added or subtracted to your final tournament score as appropriate.

Generic Comp (For all armies):

The following Common Magic Items are composition points at this event:

- -1 for the Crown of Command
- -1 for the Standard of Discipline
- -1 for Fozzrik's Folding Fortress
- +2 for the Wizarding Hat

The following criteria incur the following comp points if they are met:

- +1 if your army does not include an item which automatically dispels a spell (such as the Dispel Scroll or Rune of Spellbreaking). *This does not apply to Daemons of Chaos*
- +1 if your army does not contain a level 3+ wizard, but **DOES** contain other spell casters, spells or bound items *This does not apply to Dwarfs.*
- +3 if your army includes no magic users, spells or bound items *This does not apply to Dwarfs*
- +2 if your army does not contain a Battle Standard Bearer. *This does not apply to Tomb Kings or Vampire Counts*

Units (not characters or single models) that cost over a certain points value will incur comp points as per the list below.

- -1 per unit between 450 and 599 points inclusive
- -3 per unit between 600 and 749 points inclusive
- -5 per unit that costs 750 points or more

In addition, certain choices available to many armies incur the following comp points.

- +1 for the first non-spellcaster mounted on a Monster
- +1 for the first character mounted on a Chariot
- -1 per model who knows 3 or more spells from the Lore of Life (***Note*** Special Characters are exempt from this comp as this would have been included in their comp score).
- -1 per model who knows 3 or more spells from the Lore of Death. This is increased to -2 if the model is not troop type: infantry or monstrous infantry (***Note*** Special Characters are exempt from this comp as this would have been included in their comp score).
- -1 per spellcaster who knows spells from the Lore of Light after the second
- -1 for having 2 or more level 3+ wizards

On the following pages you will find the individual army comp. Each page will cover a different army and will have all the army-specific comp which applies in addition to the comp above.

Individual Army Composition:

Beastmen

Beastmen armies start with a comp score of +2, instead of the usual 0.

Beastmen armies may select Marks of Chaos for their units as described in End Times: Archaon; however Beastmen do not pay the additional points cost for these Marks, they are free.

Chaos Warhounds DO count towards your core points allowance

Characters may take Gifts of Chaos in addition to their magic item allowance. You still follow all the restrictions for selecting the gifts, but it is treated as a separate allowance to your magic items. Heroes may have up to 50pts, Lords up to 100pts.

Ghorros is increased to 3 wounds.

Beastmen armies use the Beastmen Ambush rule from End Times: Glotkin

Only the crew of a Beastmen chariot gain frenzy with the Mark of Khorne, not the creatures pulling the chariot (in line with the WoC FAQ).

Where a Common Magic Item is presented in the Rulebook and Warhammer Armies: Beastmen players should use the points value in the Rulebook and the rules in Warhammer Armies: Beastmen.

- -1 per spellcaster after the second if the Shard of the Herdstone is included in your list
- -1 per Tuskgor Chariot after the 3rd (including mounts)
- -1 for Slugtongue
- -1 per Doombull with the Arabyan Carpet; this is increased to -2 if the Doombull also has a 3+ ward save (***Note*** You do not receive the +1 for the Arabyan Carpet if it is on a Doombull)

- +3 if your army is Highlander
- +1 for the first of 20+ Ungor Herds
- +1 for the first 5+ Minotaurs
- +1 per 1 per unit of Centigors
- +1 for the first Giant
- +1 for the first Jabberslythe
- +1 for the first Cygor
- +1 for the first Ghorgon
- +1 for Khazrak The One Eye
- +2 for Gorthor, The Beastlord
- +2 for Moonclaw, Son of Morrslieb
- +2 for Ungrol Four-horn

Brettonnia

Brettonnian armies start with a comp score of +1, instead of the usual 0.

The following Brettonnian units gain the Devastating Charge special rule: Brettonnian Lord, Paladin, Knights of the Realm, Knights Errant, Questing Knights, Pegasus Knights, Grail Knights, and The Green Knight

Remove the 0-1 selection limit from the following units: Grail Reliquae, Pegasus Knights, and Grail Knights

Brettonnian Lords may take a single Virtue, with no points limit, in addition to their 100 point magic item allowance. You still pay the points for the Virtue and follow all of the rules around duplicating Virtues but it is treated as a separate allowance to your magic items.

Brettonnian Paladins may take a single Virtue, with a 50 point limit, in addition to their 50 point magic item allowance. You still pay the points for the Virtue and follow all of the rules around duplicating Virtues but it is treated as a separate allowance to your magic items.

Kind Louen Leoncoeur is reduced to 550pts

Note: The Grail Reliquae counts as a single model.

Where a Common Magic Item is presented in the Rulebook and Warhammer Armies: Brettonnia players should use the points value in the Rulebook and the rules in Warhammer Armies: Brettonnia.

- -1 if you have both the Silver Mirror and a Dispel Scroll
- -1 per Trebuchet after the 1st
- -1 for a lord with the virtue of Heroism

- +3 if your army is Highlander
- +1 if your general is on foot
- +1 per Hippogryph
- +1 per Lord/Paladin on foot
- +1 for the first unit of 30+ Men-at-Arms
- +1 for the first unit of 20+ Peasant Bowmen
- +1 for the first Mounted Yeomen
- +1 for the first unit of Questing Knights
- +2 for the first Grail Reliquae
- +1 if none of your knight units have more than 9 models
- +3 if you have only one of the following Knight units in your army (Realm, Errant, Questing, Grail). This is reduced to +1 if you also have Pegasus Knights

Chaos Dwarfs/Legions of Azgorh

The Chalice of Blood and Darkness can only be used after channelling and 'before a spell is cast' (step 2 of the magic phase) or 'after a spell has been resolved' (after step 4 of the magic phase).

- -1 for the first K'daai Destroyer, -2 for each K'daai Destroyer after the first
- -1 for the Chalice of Blood and Darkness
- -2 if 2 Death Shrieker Rockets are included
- -2 if 2 Magma Cannons are included
- -1 per Hellcannon
- -1 per Infernal Castellan after the 1st
- -1 if your army contains more than 4 War Machines (both the Hellcannon and Iron Daemon count as War Machines for this purpose)
- +2 if your army is Highlander
- +1 for the first unit of Chaos Dwarf Infernal Guard armed with Fireglaves
- +1 per unit of Chaos Dwarf Infernal Ironsworn
- +1 per unit of K'daai Fireborn
- +4 if your army includes no War Machines (both the Hellcannon and Iron Daemon count as War Machines for this purpose)
- +1 for the first unit of 40+ Hobgoblin Cutthroats

Daemons of Chaos

All mounts, except ridden monsters, are ignored for leadership purposes for the Spell Treason of Tzeentch. In the case of chariots the creatures pulling the chariot and the chariot's leadership are ignored.

The Tally of Pestilence has no affect while Epidemius is held in reserve.

Hits from the Reign of Chaos are always treated as having hit the front arc of the targeted unit.

Daemonic characters with more than 1 magic weapon can only benefit from the effects of 1 weapon at a time. They must declare at the start of the player turn which weapon the character is using; any other magic weapons have no effect whatsoever for the duration of that turn.

Mono God Armies - If your army consists solely of Daemons of a single Chaos God you incur the following comp points:

- +1 if your army consists solely of Daemons of Tzeentch – in addition you may ignore the comp for multiple Lore of Tzeentch casters
- +2 if your army consists solely of Daemons of Slaanesh
- +2 if your army consists solely of Daemons of Khorne – in addition the comp for having 2 Skull Cannon is reduced to -2
- -4 for Epidemius
- -4 for Kairos Fateweaver
- -1 per Herald of Nurgle in the army more than units of 20+ Plaguebearers
- -1 per caster using the Lore of Tzeentch after the 2nd
- -1 per unit of Beasts of Nurgle
- -1 per unit of Beasts of Nurgle with 6+ models, this is in addition to the above comp
- -1 per Plague Drone unit after the 1st
- -1 for the first Skull Cannon, -2 for the second Skull Cannon

- +1 if your army is Highlander
- +1 for the first Daemon Prince
- +1 for the first Keeper of Secrets
- +1 for the first Great Unclean One
- +1 for the first Blood Throne of Khorne
- +1 for the first unit of 15+ Daemonettes
- +1 for the first unit of 15+ Bloodletters
- +1 for the first Seeker Chariot of Slaanesh or Hellflayer of Slaanesh after the 1st
- +1 for the first Burning Chariot of Tzeentch
- +1 for the first unit of 4+ Bloodcrushers
- +1 for the first unit of 3+ Nurglings
- +1 for the first Exalted Seeker Chariot of Slaanesh
- +1 for Skarbrand
- +1 for Ku'Gath Plaguefather

Dark Elves

The Cauldron of Blood does not allow re-rolls on ranged attacks or spells.

The army list does not need to state any Lore(s) for Morathi. She chooses her Lore(s) at the start of each game as per her special rules.

A model with Hatred (High Elves) has Hatred against all models taken from the High Elf Army Book.

- -4 for Morathi
- -1 per character mounted on a Dark Steed or Pegasus who also has a Sea Dragon Cloak
- -1 for the Cloak of Twilight
- -1 per Cauldron of Blood (***Note*** Despite this being a chariot mount, a model mounted on the Cauldron does not get the +1 for a character mounted on a chariot)
- -1 per Reaper Bolt Thrower after the 2nd
- -1 per unit of 26+ Witch Elves
- -1 per unit of 26+ Har Ganeth Executioners
- -1 per unit of Doomfire Warlocks
- -1 if your army includes more than 10 Doomfire Warlocks, this is in addition to the above comp
- -1 per unit of Dark Riders after the 2nd

- +1 if your army is Highlander
- +2 for the first Supreme Sorceress on Black Dragon
- +1 for the first High Beastmaster
- +1 for the first Fleetmaster
- +1 for the first Manticore mount (excluding High Beastmaster mounts)
- +1 for the first unit of 20+ Dreadspears
- +1 for the first unit of 20+ Bleakswords
- +1 for the first unit of Cold One Knights
- +1 for the first Sourgerunner Chariot (excluding mounts)
- +1 for the first Bloodwrack Medusa
- +1 for the first Bloodwrack Shrine
- +1 for the first unit of Sisters of Slaughter
- +1 for Lokhir Fellheart
- +1 for Kouran Darkhand
- +1 for Tullaris Dreadbringer

Dwarfs

Dwarf armies start with a comp score of +1, instead of the usual 0

The banner of Lost Holds can be taken on the BSB or a unit of slayers when Ungrim Ironfist is included (and when this increases the slayer units magic standard allowance to 100pts).

Thorgim Grudgebearer is reduced to 625pts

- -1 if 2+ Cannons are included; this is increased to -2 if any have runes
- -1 if 2+ Organ Guns are included; this is increased to -2 if any have runes
- -1 if 2+ Grudge Throwers are included; this is increased to -2 if any have runes
- -1 if your army contains more than 4 War Machines (the Anvil of Doom does not count for this)
- -1 per Rune of Spellbreaking after the 2nd
- -1 per Gyrocopter after the 2nd
- -1 for Grimm Burlocksson
- -1 per Rune of Stoicism
- -1 per Master Rune of Groth One-Eye when taken on a unit of Hammerers

- +2 if your army is Highlander
- +1 for the first unit of Slayers over 100 points, this does not apply if there are more than 1 Giant Slayer per 5 Slayers
- +1 for the first unit of Miners
- +1 for the first unit of 20+ Dwarf Warriors
- **+1 for the first unit of 20+ Thunderers**
- +1 for the first Dwarf Lord
- +1 for the first Runelord, this is increased to +2 if mounted on an Anvil of Doom
- +1 for the first Daemon Slayer
- +1 for the first Dragon Slayer
- +1 for Ungrim Ironfist
- +1 for Belegar Ironhammer
- +2 for Thorek Ironbrow
- +3 if the army DOES NOT include any items which automatically dispel a spell (this replaces the generic comp point for auto-dispel items)
- +4 if the army includes no War Machines (the Anvil of Doom does not count for this)

High Elves

The -1S from the Blizzard Aura special rule for Frostheart Phoenixes does not stack.

The High Magic Lore Attribute increases all Ward Saves as well as all conditional Ward Saves a model may have. If a model only has conditional Ward Saves then it also receives a 6+ Ward Save.

The army list does not need to state any Lores for Alarielle. She chooses her Lore(s) at the start of each game as per her special rules.

The army list must state if Teclis is using High Magic or Battle Magic. If you are choosing Battle Magic, then Teclis may pick his spells at the start of every game.

- -1 for the Banner of the World Dragon if it is on the Battle Standard Bearer
- -3 for the Banner of the World Dragon if it is on a unit Standard Bearer
- -1 for the first Frostheart Phoenix, -2 per Frostheart Phoenix after the 1st (this EXCLUDES Frostheart Phoenixes taken as mounts, however you can never gain the +1 for a character mounted on a Monster when taking a Frostheart Phoenix as a mount)
- -1 for Caradryan if mounted on Ashtari
- -1 per character mounted on an Elven Steed who also has Dragon Armour after the 2nd
- -1 for the Book of Hoeth
- -1 per unit of Ellyrian Reavers after the 3rd
- -1 per Eagle Claw Bolt Thrower after the 2nd
- -1 per unit of 26+ White Lions of Chrace
- -1 per unit of 11+ Dragon Princes
- -3 for Teclis
- -3 for Alarielle the Radiant

- +1 if your army is Highlander
- +2 for the first Archmage on Dragon
- +2 for the first Dragon Mage
- +1 for the first unit of 20+ Spearmen
- +1 for the first Lion Chariot (excludes mounts)
- +1 for the first Skycutter Chariot (excludes mounts)
- +1 for the first Flamespyre Phoenix
- +1 per unit of 3+ Great Eagles
- +1 for Tyrion
- +1 for Korhil

Lizardmen

Models with the Predatory Fighter rule may benefit from it when fighting from the second or subsequent ranks.

Piranha Blade only gives Multiple Wounds (D3) Special Rule while being used in close combat.

Burning Alignment and The Deliverance of Itza target all enemy units within the specified distance of the spells. This applies even if the enemy unit is engaged in close combat or in the rear/flank arc of the model casting the spell.

Tiktaq'To may join units of Terradon Riders.

Madamundi can be taken for 625pts

Chakax is increased to 3 wounds.

- -1 for a Slann Mage-Priest with both Harmonic Convergence and the Channeling Staff
- -1 per Saurus character on Cold One after the 1st
- -1 if you have both the Cube of Darkness and a Dispel Scroll
- -1 per unit of Skink Skirmishers after the 3rd
- -1 per unit of Chameleon Skinks after the 1st
- -1 per unit of Skink Cohorts costing under 100 points, after the 2nd
- -2 for Tetto'eko

- +3 if your army is Highlander
- +1 for a Saurus Scar-Veteran Battle Standard Bearer
- +1 per Slann Mage-Priest with Higher State of Consciousness
- +1 for the first Skink Cohort containing at least 2 Kroxigor
- +1 for the first unit of Ripperdactyl Riders
- +1 for the first Bastiladon with the Ark of Sotek
- +1 for the first unit of 4+ Kroxigor
- +1 for the first unit of Jungle Swarms
- +1 for the first Stegadon (***Note*** this does NOT include Ancient Stegadons)
- +2 for the first Trogladon
- +1 for the first unit of 2+ Razordon
- +1 for Chakax
- +1 for Gor-Rok
- +1 for Tiktaq'to
- +1 for Oxyotl
- +2 for Tehenhauin. If Tehenhauin is your army General and your army does not include any Saurus characters, the negative comp for Skink units do not apply)

Ogre Kingdoms

- -1 for the Hellheart
- -1 for the Runemaw
- -1 for the Dragonhide Banner
- -1 per unit of Mournfang Cavalry after the 1st
- -2 if 2 Ironblasters are included in your army
- -1 per unit of 1 Sabretusk after the 2nd

- +2 if your army is Highlander
- +2 if no Monstrous Infantry unit is larger than 6 models
- +1 per Big Name
- +1 for the first Hunter
- +1 for the first unit of 20+ Gnoblar
- +1 for the first unit of 5+ Sabretusks
- +1 for the first unit of Yhetees
- +1 for the first Gnoblar Scraplauncher
- +1 for the first Giant
- +1 for the first Thundertusk
- +1 if your army does not include any Ironblasters
- +1 for Skrag the Slaughterer
- +1 for Golgfag Maneater
- +2 for Bragg the Gutsman
- +2 for Greasus Goldtooth

Orcs & Goblins

A shot from a doom diver war machine may never hit more than a single unit; if two units are struck by a doom diver marker the controlling player decides which one, they hit. (This is to avoid issues with the size of the marker etc).

- -1 if you have more than 6 Fanatics
- -1 for the Lucky Shrunken Head, this is increased to -2 if a unit of 30+ Savage Orc Big'uns are also included
- -2 if 2 Doom Diver Catapults are included
- -1 if 2 Rock Lobbers are included
- -1 per Mangler Squig

- +3 if your army contains only Goblins
- +5 if your army contains only Orcs

For the purposes of the above comp points Trolls and Giants can count as either Orcs or Goblins as you want. War Machines without Orc Bully's count as Goblins, War Machines with Orc Bully's count as Orcs. Arachnarok Spiders, Squig Herds, Squig Hoppers, Snotlings and Snotling Pump Wagons and Mangler Squigs count as Goblins.

- +2 if your army is Highlander
- +3 if your army contains no War Machines
- +1 for the first unit of 20+ Orc Arrer Boyz
- +1 for the first unit of 20+ Orc Boyz
- +1 for the first unit of 10+ Forest Goblin Spider Riders
- +1 for the first unit of 20+ Goblins
- +1 for the first unit of 3 or more Stone Trolls
- +1 for the first unit of 20+ Black Orcs
- +1 for the first unit of Snotlings
- +1 for the first unit of Orc Boar Boyz
- +1 for the first unit of Savage Orc Boar Boyz
- +1 for the first Arachnarok, this is increased to +2 if it also has the Catchweb Spidershrine
- +1 for the first Giant
- +1 for Azhag the Slaughterer
- +2 for Grom the Paunch
- +1 for Gitilla da Hunter
- +1 for Snagla Grobspit

Skaven

The Skaven Spell Cracks Call may be cast into combat and through friendly units as it does not have a target.

Other Skaven Spells may not be cast into combat unless they specifically say so or mention it in their description.

A charging Skaven unit that has moved forward d6 inches as a result of a Screaming Bell allows no charge reactions.

The army list does not need to state any Lores for a Skaven Grey Seer or Verminlord as they can freely mix Spells of Plague and Ruin as per their special rules.

A Hellpit Abomination that has had its strength reduced or increased will use the new strength when working out any of its special attacks.

Where a Common Magic Item is presented in the Rulebook and Warhammer Armies: Skaven players should use the points value in the Rulebook and the rules in Warhammer Armies: Skaven.

You do NOT receive the +1 for a character mounted on a chariot for models mounted on a Screaming Bell or Plague Furnace

- -1 if you take 2 of the following, -2 if you take 3 of the following, and -3 if you take all 4: Brass Orb, Power Scroll, Storm Banner or Doom Rocket
- -1 for the first Unbreakable unit, -2 per Unbreakable unit after the first (excluding Rat Swarms)
- -1 per Warlock Engineer after the 3rd
- -1 per unit of Giant Rats with less than 10 models after the 2nd
- -1 per unit of Rat Swarms with less than 3 models after the 1st
- -1 per unit of Skavenslaves after the 1st
- -1 per unit of Gutter Runners after the 2nd
- -2 if 2 Doomwheels are included
- -2 if 2 Warp Lightning Cannons are included
- -1 per Hell Pit Abomination

- +2 if your army is Highlander
- +1 for the first unit of 20+ Night Runners
- +1 for the first unit of 20+ Giant Rats
- +1 for the first unit of Rat Ogres
- +1 for the first unit of Plague Censer Bearers
- +1 for the first unit of Poisoned Wind Globadiers
- +1 for the first Great Pox Rat
- +2 for the first Vermin Lord
- +1 for Thanquol
- +1 for Ikit Claw
- +1 for Throt the Unclean
- +1 for Tretch Craventail

The Empire

The Empire do NOT receive the +1 for a character mounted on a chariot for models mounted on a War Altar of Sigmar. The Empire can take units from the Tamurkhan book as indicated in the Empire Bestiary section.

- -1 if you have no Core Infantry
- -2 if 2 Great Cannons are included
- -2 if 2 Helblaster Volley Guns are included
- -1 per unit of Demigryph Knights after the 1st
- -1 for the first Steam Tank, -3 per Steam Tank after the first
- -1 if your army includes both 1+ Steam Tanks and a Lore of Life wizard, this is in addition to any other comp on Steam Tanks and the Lore of Life
- -1 if your army contains more than 4 War Machines (Steam Tanks count as War Machines for the purpose of this)
- -1 if you have 50 or more wounds worth of 1+ save models in your army

- +1 if your army is Highlander (***Note*** for the purposes of Highlander detachments are treated as different to a parent unit of the same type; e.g. you can include one unit of Halberdiers and one detachment of Halberdiers and still claim the Highlander comp point)
- +2 for the first Wizard Lord on Griffon
- +1 for the first Wizard Lord on a Luminark of Hysh
- +1 for the first Wizard Lord on a Celestial Hurricanum
- +1 for Markus Wulfhart
- +1 for Marius Leitdorf
- +1 for the first unit of 20+ Free Company
- +1 for the first unit of 20+ Spearmen
- +1 for the first unit of 20+ Swordmen
- +1 for the first unit of 20+ Greatswords
- +1 for the first unit of Outriders
- +1 for the first unit of Flagellants
- +1 per Mortar
- +1 per Helstorm Rocket Battery

Tomb Kings

Tomb King armies start with an initial comp score of +3, instead of the usual 0.

Tomb King armies can also take 2600point army, instead of the usual 2500pts

Tomb King armies may march when within 12" of the army General.

Change the last sentence of The Restless Dead (Lore of Nehekhara Lore Attribute) to 'Units with the Animated Constructs special rule can only ever recover a single lost wound in this way, per spell cast'.

- -1 per Heirotitan
- -1 per 10 (or part of 10) Skeleton Archers in the army after 50
- -1 per unit of Necropolis Knights after the 1st
- -1 per Casket of Souls
- -1 for Screaming Skull Catapults after the 1st
- -1 for Ramhotep the Visionary if the army only contains one unit of animated constructs
- -1 for High Queen Khalida
- -1 for Arkhan the Black

- +3 if your army is Highlander
- +2 for the first Tomb King
- +1 for a Tomb Herald Battle Standard Bearer
- +1 for the first unit of 20+ Skeleton Warriors (not Archers)
- +1 for the first unit of Skeleton Horsemen (not Horse Archers)
- +1 for the first unit of Tomb Swarms
- +1 for the first unit of Ushabti
- +1 for the first unit of Sepulchral Stalkers
- +1 for the first Necrosphinx
- +1 for the first unit of 20+ Tomb Guard
- +1 for Settra the Imperishable
- +1 for Prince Apophas
- +1 for The Herald Nekaph

Vampire Counts

When making their special movement attack, Hexwraith models measure distance moved from starting point to enemy unit they are attacking and back to a legal position. The distance moved cannot exceed their movement value or double this if they marched. They may reform inside an enemy unit.

Death Shriek and Ghostly Howl are not considered shooting attacks.

You must show your opponent your 'pool' of summonable models at the start of each game; you may not share models or borrow from a friend during the game.

Summoned units are NEVER scoring units. (Please note: no part of the model may take more wounds than it currently has remaining.)

- -1 per Vampire Lord with Red Fury
- -1 per Quickblood
- -1 per Ethereal character after the 1st
- -1 per unit of Dire Wolves after the 3rd
- -1 per unit of 8+ Crypt Horrors
- -1 per character mounted on a Nightmare, Barded Nightmare or Hellsteed after the 2nd
- -1 for the second unit of Hexwraiths, -2 for the third unit of Hexwraiths
- -1 per unit of 1 Spirit Host after the 1st
- -1 for the first Terrorgheist, -2 for each Terrorgheist after the first (excluding mounts)
- -1 if your army includes more than 2 Deathshrieks
- -2 for Count Mannfred

- +1 if your army is Highlander
- +2 for the first Zombie Dragon
- +2 for the first Abyssal Terror
- +2 for the first Coven Throne
- +1 for the first unit of Bat Swarms
- +1 for the first Corpse Cart
- +1 for the first unit of 20+ Grave Guard
- +1 for the first unit of 4+ Vargheists
- +2 for the first Black Coach
- +1 for the first unit of Blood Knights
- +1 for Vlad von Carstein
- +1 for Isabella von Carstein
- +1 for Krell, Lord of Undeath, this is increased to +2 if the army also includes Heinrich Kemmler

Warriors of Chaos

Soul Feeder may NOT be used to gain wounds back from both Stomps and Breath weapon attacks.

Mono God Armies - If your army consists solely of units/characters with the same Mark of Chaos you may apply the below comp. Note that anything that does not have a Mark of Chaos, or an option for one, can all be included in such an army without costing it this comp.

- +1 for the Mark of Slaanesh
- +1 for the Mark of Tzeentch
- +2 for the Mark of Khorne

- -1 per character with a 3+ ward save, an additional -1 should that character also have the Third Eye of Tzeentch or a 2+ armour save or better (this excludes special characters)
- -1 per Daemonic Mount
- -1 per Disc of Tzeentch
- -1 per Core Chaos Chariot after the 2nd
- -1 if 2 Chimera's are included, - 3 if 3 Chimera's are included. There is an additional - 1 if any have the Regenerating Flesh upgrade
- -1 per unit of Skullcrushers of Khorne after the 1st
- -1 per Hellcannon
- -1 for Throgg the Troll King
- -1 per unit of Chaos Trolls taken as a Core choice
- -1 for Galrauch
- -1 per Daemon Prince, an additional -1 if he has Daemonic Flight and -1 if he has a 2+ armour save or better

- +1 if your army is Highlander
- +1 for the first unit of 20+ Chaos Marauders
- +1 for the first unit of Dragon Ogres
- +1 for the first unit of 10+ Forsaken
- +1 for the first Warshrine (excluding Warshrines with the Mark of Tzeentch)
- +1 for the first unit of 10+ Chosen
- +1 for the first Giant
- +1 for the first unit of 6+ Chaos Knights
- +1 for the first Shaggoth
- +2 for the first Slaughterbrute
- +2 for the first Mutilath Vortex Beast
- +1 for the first unit of Hellstriders of Slaanesh
- +1 for Kholek Suneater
- +1 for Valkia the Bloody

Wood Elves

Wood Elves armies may duplicate their enchanted arrows across more than one unit.

If you chose to mount the sisters of Twilight on Gwindalor, then treat them as a ridden monster for the purposes of attacking them or allocating/ randomising hits on them. For any other purpose treat them as monstrous cavalry as per their army book entry.

Warhawk Riders can take magic arrows

- -1 per 10 (or part of 10) models with Trueflight and/or Hagbane Tip arrows in the army after 40
- -1 per Spellweaver on the Lore of Shadow
- -1 per character mounted on an Elven Steed after the 1st
- -1 per unit of Sisters of the Thorn
- -1 per unit of Wild Riders after the 1st
- -1 per unit of Waywatchers after the 1st
- -1 per unit of Deepwood Scouts after the 2nd

- +3 if your army is Highlander
- +1 for the first Unicorn (taken as mounts)
- +1 for the first Great Stag (taken as mounts)
- **+1 Wood elf Glade Lord**
- +1 for the first unit of 20+ Eternal Guard
- +1 for the first unit of **10+ Dryads**
- +1 for the first unit of Warhawk Riders
- +2 for the first unit of 20+ Wildwood Rangers
- +1 for the first unit of 8+ Wardancers
- +1 for the first Treeman Ancient
- +1 for the first unit of 3+ Great Eagles
- +1 for the first Shadowdancer
- +1 for the first Branchwraith
- **+2** for Araloth
- +1 for Drycha
- +2 for Orion
- +1 for the Sisters of Twilight if mounted on Gwindalor
- +3 if your army contains no Elves (Orion is NOT treated as an Elf for the purposes of this)

Scenarios:

In London Legends, scenarios will apply in all five games, and scoring units are relevant for all of them. A scoring unit is defined as follows:

- Infantry units with at least 10 models & a Unit Standard Bearer.
- Cavalry units with at least 5 models & a Unit Standard Bearer.
- Monstrous Infantry units with at least 3 models & a Unit Standard Bearer.
- Monstrous Cavalry units with at least 3 models & a Unit Standard Bearer.
- Chariot units with at least 3 models & a Unit Standard Bearer.

As long as these Scoring Units meet the above requirements before a game. They remain Scoring until the Unit Standard Bearer is destroyed!

- Finally, the Battle Standard bearer can join a unit and this unit will count as scoring provided that: a) he joins the unit at the start of the game and remains with the unit, b) the unit begins the game with the minimum number of models (*Infantry 10, Cavalry 5, Fast Cavalry 10, Monstrous Infantry/Beasts/Cavalry and Chariots 3, War beasts 5*) and c) at least one model is remaining. A unit with a standard bearer and a BSB only counts once for the purpose of scoring.

Units that are NEVER considered scoring:

- Characters on their own
- Fast Cavalry
- Monsters (including Ridden ones).
- Units that are Fleeing.
- Units with Fly/Hover Special Rule (including the BSB).
- Summoned units

Mission Objectives

Scoring will follow a modified version of the 20-0 system.

Difference in Victory Points	Winner's Tournament Points	Loser's Tournament Points
0-200	10	10
201-500	11	9
500-800	12	8
801-1100	13	7
1101-1400	14	6
1401-1700	15	5
1701-2000	16	4
2000+	17	3

The winner of the secondary objective gains 3 Tournament points whereas the loser will lose 3 tournament points. If there is no winner, or if both players achieve the secondary objective, then no additional tournament points are gained or lost.

Tournament points for winning the secondary objective are added/subtracted immediately after each round

Game 1 – Capture the flags

Deployment

The player choosing the Deployment Zone decides if they want to be the attacker or the defender. The attacker must deploy more than 9" from the Centre Line if entirely within a quarter of the board's length from either short Board Edge (18" on a 72" board), and more than 15" from the Centre Line elsewhere. The defender does the opposite: more than 15" away from the Centre Line if within a quarter of the board's length from the short Board Edge, and more than 9" away from the Centre Line elsewhere.

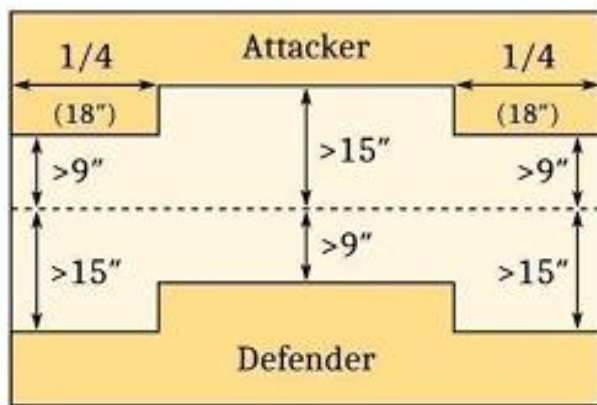

Objective

Capture the Flags

Your mission is to eliminate enemy scoring units.

After Spell Selection, each player reveals how many Scoring units they have in their list. The opposing player then picks 3 scoring units to Destroy. If a player only has 2 Scoring units, the opposing player then gets to pick any one unit (in this case) on the opposing players list, this unit then becomes Scoring. The same logic applies if the player brings 0 or 1 Scoring unit. The player who destroys the most Scoring units (capped at 3, if both kill 3 Scoring units then no player wins the Secondary Objective) wins this Secondary Objective.

Game 2 – Control

Deployment

Deployment Zones are areas more than 12" away from the Centre line.

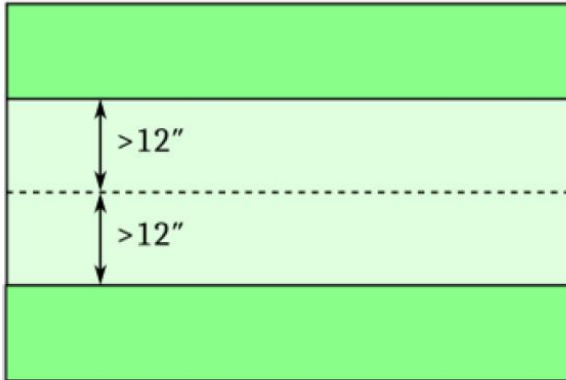

Objective

The Mission is 'Control'

At the end of the game divide the board into six, 2*2 squares (24*24")

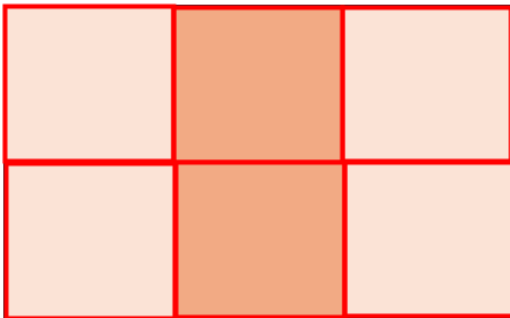

Add up the total number of scoring units in each square. If a unit is straddling the line between squares it is considered to be in whichever square is covered by the majority of its base. If there is no clear majority, the owning player must choose which square the unit is in.

The player who has the most scoring units in each square controls it.

Mission points are awarded at the end of the game as follows:

- 2 mission points if you hold the square in the middle of your opponent's half of the board.
- 1 mission point for any other square you hold.

The player with the most mission points wins the objective.

Game 3 – The Holy Ground

Deployment

Deployment Zones are areas more than 8" away from the Centre Line. Units must be deployed more than 20" away from enemy units. During their first 3 deployment turns, each player must deploy a single unit if possible, and cannot deploy any Characters unless they have to. Units using Special Deployment, such as Scout, ignore these restrictions and follow their Special Deployment rules.

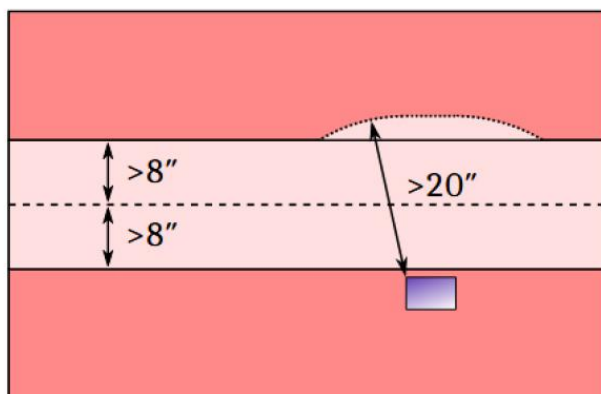

Objective

The Mission is Desecrate the Holy Ground

You must desecrate your opponent's holy ground while protecting yours.

After Spell Selection, both players choose a Terrain Feature that isn't Impassable Terrain and that is not fully inside their Deployment Zone, starting with the player who chose their Deployment Zone (note that both players may choose the same Terrain Feature). A player captures their opponent's chosen Terrain Feature if any of the player's Scoring Units are inside that Terrain Feature at the end of the game. If a player captures their opponent's chosen Terrain Feature while not allowing their own to be captured, they win this Secondary Objective. (Armies that deploy Terrain Feature like Wood Elves, this Terrain Feature cannot be used for Scoring purposes).

Game 4 – Secure Target

Deployment

Draw a line from the middle of the left short table edge to the bottom right corner as shown below.

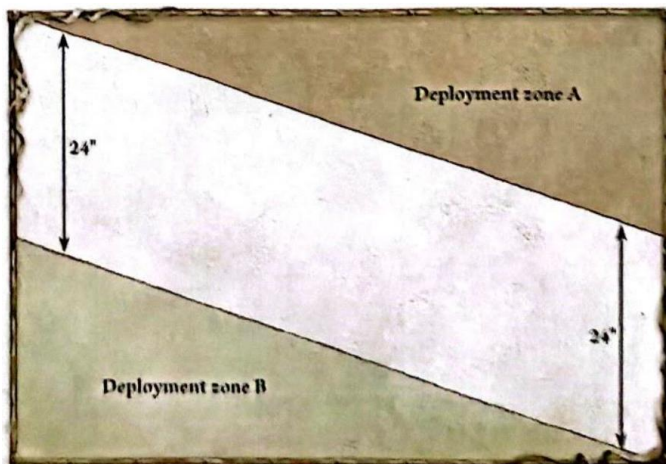

Objective

The Mission is Secure Target

Your mission is to ensure that critical resources do not fall into enemy hands.

Immediately after determining Deployment Zones, place three objective markers – the first in the centre of the battlefield, the other two halfway between the centre marker and the middle of the short table edges as shown below.

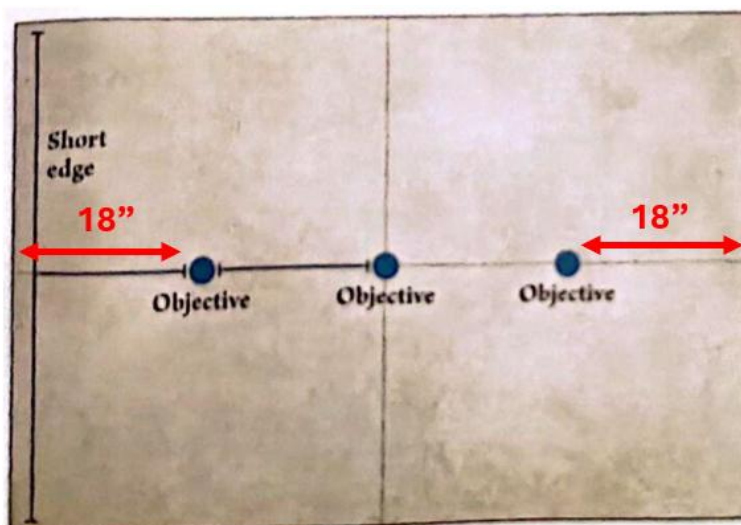

A marker is controlled by the player with the most Scoring Units within 6" of the centre of the marker. If a unit is within 6" of the centres of both markers, it only counts as within 6" of the centre of the marker which is closest to its Centre (randomise if both markers' centres are equally close).

Game 5 – Hold the Ground

Deployment

The player choosing the Deployment Zone also chooses a short Board Edge and the other player gets the opposite short Board Edge. Deployment Zones are areas more than 12" away from the Centre Line and more than 1/4 of the board's length from the opponent's short Board Edge (18" on a 72" board). When declaring Special Deployment, players may choose to keep up to two of their units as reinforcement. These units follow the rules for Ambushing units, except that they must be placed touching the owner's short Board Edge when they arrive.

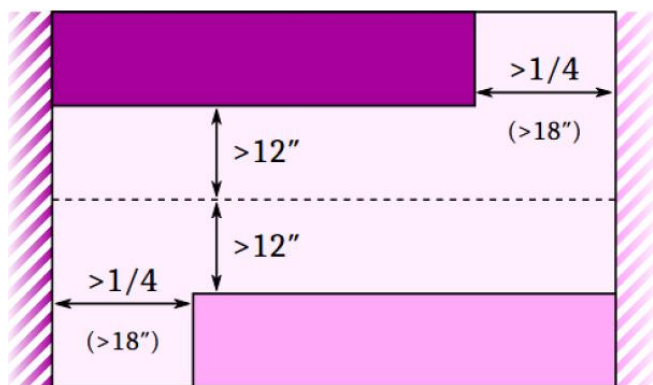

Objective

The Mission is 'Hold the Ground'

You must secure and hold the centre of the Battlefield. Mark the centre of the board.

At the end of each Game Turn after the first, the player with the most Scoring Units within 6" of the centre of the board gains a counter. At the end of the game, the player with the most such counters win this Secondary Objective.

The Event Awards

Event Winners

Three Factors will be used to determine the winner of LONDON LEGENDS:

1. Firstly, we will take all your Tournament Points from your gaming (Max 100). Then we will add or subtract your comp score from this number.
2. Secondly, we will add any Tournament Points that you have gained for your painted armies.

The person who has the highest score once all the numbers have been added will – to great fanfare and a guard of honour with 12 gun salute – be declared the winner of LONDON LEGENDS!

Best Painted Army Display

On Sunday during the luncheon interval, players are asked to display their armies with their name written in front. The event organisers have convened an expert painting panel with 189 years of combined painting experience, and we will judge which army is, in our esteemed judgement, the best and most impressive.

Painting Points:

You may attend with a completely unpainted or unbased army. There is an expectation that your army is assembled. However, if you do not adhere to any one of the below conditions, there is a possible 10 Tournament Points you could miss out on!

- Is it fully painted & based?
- Is the army 3-colour minimum?
- Does the army have a consistent theme (i.e., painted the same livery, based the same etc.)? If you say for example, meet two of these requirements, you will score 7 Tournament Points. If you only meet one requirement, you will score 4 Tournament Points. And if you meet the full painting requirement, you will score 10 Tournament points.

Sportsmanship

Sportsmanship is a crucially important part of Warhammer. As poor sportsmanship and bad behaviour is thankfully so rare in our community, we do not wish to be unduly formal about policing it- because we trust you. There are 5TPs available for sportsmanship – one per game – and these will automatically be granted, apart from in the event of a complaint.

However, if you feel your opponent has behaved badly – including cheating or by being excessively grumpy (beyond what one might reasonably expect in an often frustrating and exhilarating game of dice!) – then please come to us at any point in the event to let us know and we will take appropriate action.

Tournament points for painting, sportsmanship and comp score are added at the end of the tournament.

FAQs:

- All current WFB FAQ's available from Games Workshop/ ForgeWorld will be used at this event alongside this document. If this FAQ or comp pack contradicts any rules found in one of those FAQ's this document takes precedent.
- Open ground does count as terrain for the purposes of the Curse of Anraheir spell.
- Only 1 character may charge out of a unit per phase.
- Birona's Timewarp cannot increase a unit's movement value above 10, so max march would be 20 inches.
- The wizard who miscast cannot get a Look out Sir from damage from a miscast template.
- Iceshard Blizzard & Pha's Protection affects anything that fires in the same way as a warmachine. This would include, Skull Cannons, Ironblasters, Hellcannons, Cygors etc.
- Cannon balls cannot bounce through impassable terrain or buildings. The cannon ball will however inflict hits on any unit garrisoning a building as normal.
- Ironcurse Icon works against all Weapons that fire like a War Machine.
- Cannons mounted on chariots, such as the Ironblaster, Skullcannon and steam tank may not pivot in the shooting phase and like all other cannons must shoot in a straight line forward from the barrel.
- A model in a challenge cannot be affected by any enemy breath weapons or impact hits done by models from outside the challenge.
- A Character model may make way at the start of any round of close combat.
- Immunity to Killing Blow also gives immunity to Heroic Killing Blow.
- A model with Always Strike First and with equal or higher initiative than an enemy model with Always Strike First and Always Strike Last will get to re-roll to hit rolls in close combat against that model.
- If the general character model is killed but his mount survives you still receive the +100vp for killing the general, and the fortitude points for slaying the general.
- If 2 characters have incompatible base sizes to the unit they are joining then they are placed on either side of the unit. A 3rd character with an incompatible base size may not join the unit.

We look forward to seeing you at **LONDON LEGENDS 2026**